

Product introduction

Rubber-disc check valve can be installed in water supply or pump's outlet to prevent the fluid back. The valve disc coated with NBR or EPDM, so it can increase the service life and decrease noise. Suitable for horizontal or vertical up positions

configuration drawing

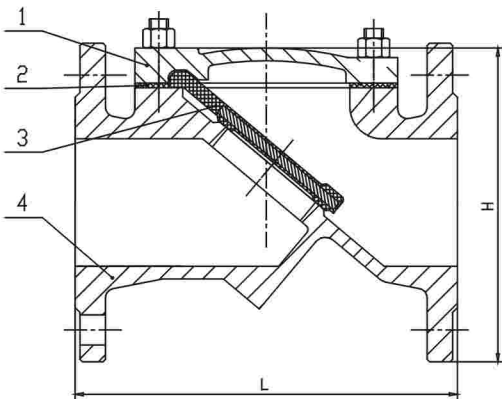

Specification

Nominal pressure	1.0~2.5
Pressure test	GB/T13927-1992
Face to face dimension	GB/T1221-1989
阀门标志	GB/T1220-1989
Working pressure	≤80℃
Suitable medium	water, sewage, seawater

Main part material

Number	Name	Material
1	Bonnet	Cast Iron, Ductile Iron, Carbon steel, Stainless steel
2	Gasket	Asbestos
3	Disc	Carbon steel+NBR
4	Body	Cast Iron, Ductile Iron, Carbon steel, Stainless steel

Installation drawing

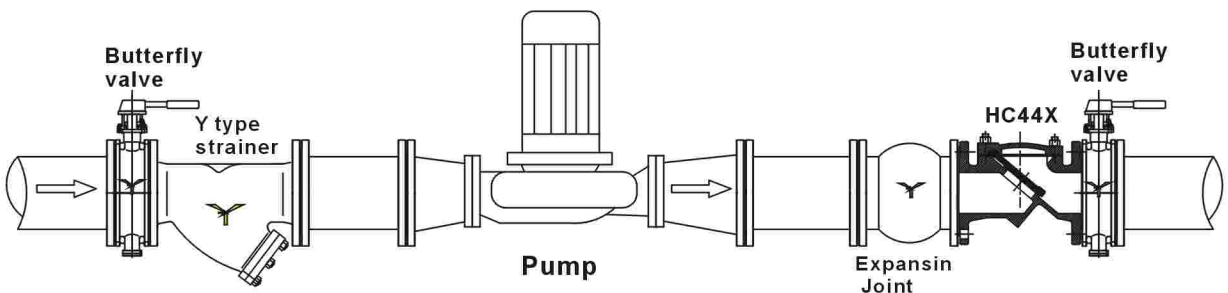

Main Dimension

公称通径 DN (mm)	40	50	65	80	100	125	150	200	250	300	350	400	500	600
L(mm)	165	203	216	241	292	330	356	495	622	698	787	914	978	1295
H(mm)	180	190	210	220	250	280	315	370	430	475	550	600	650	700