

Product introduction

Differential pressure control valve is used for water supply and backwater of the air conditioning system to ensure the pressure difference and improve the availability of the system. And the valve can keep the constant pressure difference and reduce the noise of the system and damage of the equipment for too large pressure difference.

configuration drawing

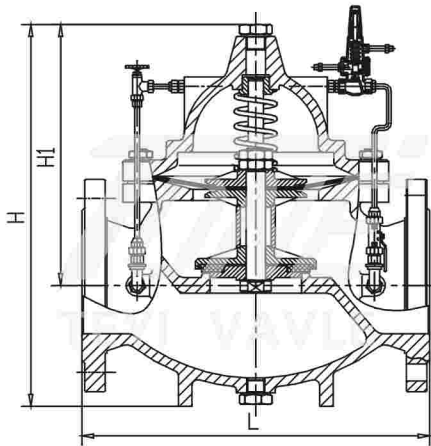

Installation drawing

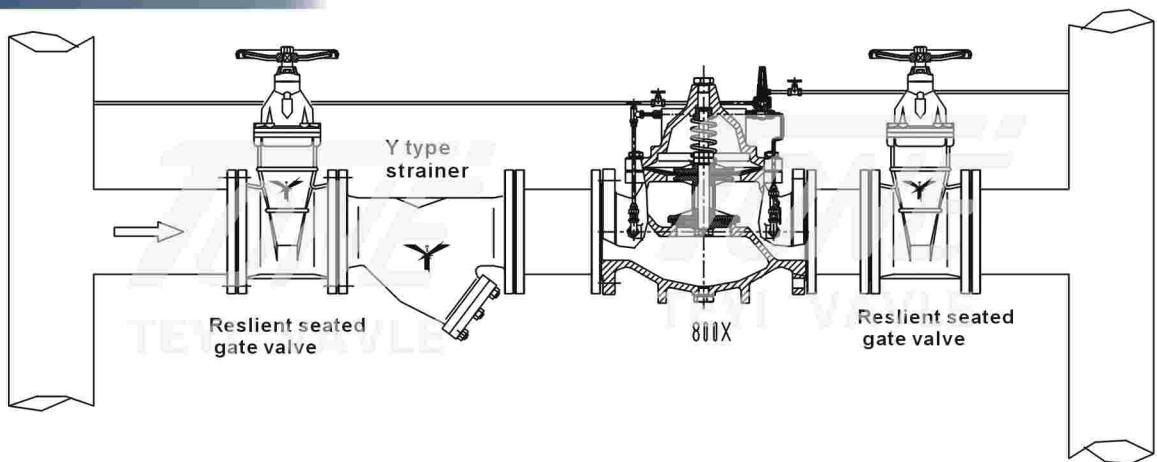

Main Dimension

公称通径 DN (mm)	50	65	80	100	125	150	200
L(mm)	230	250	241	292	330	356	495
H(mm)	270	305	320	400	455	502	636
H1(mm)	200	210	220	260	310	342	413
公称通径 DN (mm)	250	300	350	400	450	500	600
L(mm)	622	698	787	900	978	1075	1230
H(mm)	750	913	913	1035	1035	1300	1370
H1(mm)	510	600	600	685	685	880	950