

Product introduction

300X slow close check valve is a kind of intelligent valve, installed at the outlet of pump in highbuilding's feeding system and other feeding system to prevent the fluid flowing backwards, water-hammering and water-hitting. This kind of valve has the function of electric valve, non return valve and water-hammering eliminator and improves the safety of feeding system. It has the principal of slow-open, quick-close and slow-close into one to prevent water-hammering when start or stop pump. Just operate the pushing button for the pump motor and the valve can auto matically open or close according to the operating procedure with little pressure loss and large flow rate. It is suitable for DN600mm or less pipeline.

configuration drawing

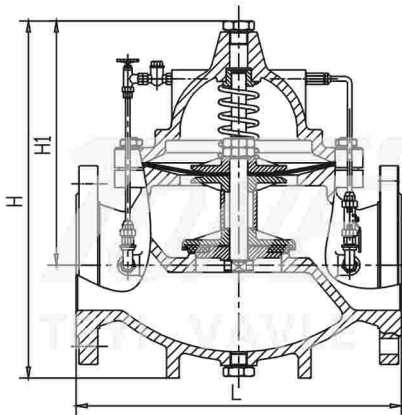

Installation drawing

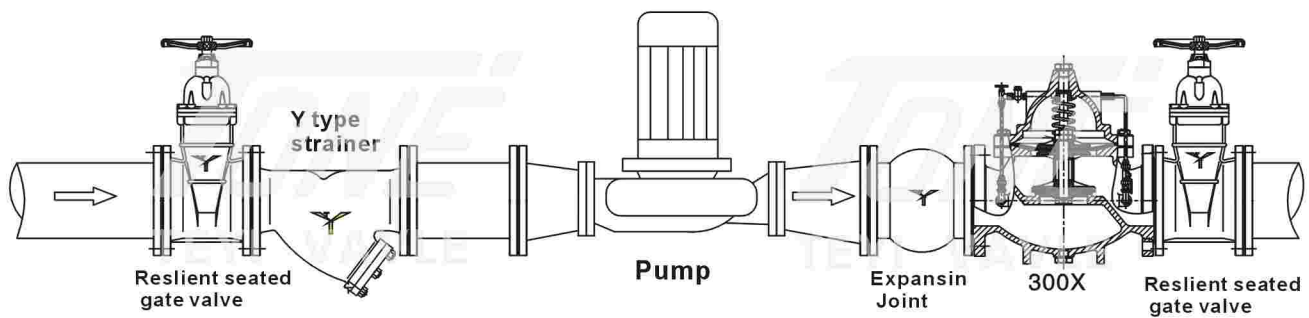

Main Dimension

公称通径 DN (mm)	50	65	80	100	125	150	200
L(mm)	230	250	241	292	330	356	495
H(mm)	270	305	320	400	455	502	636
H1(mm)	200	210	220	260	310	342	413
公称通径 DN (mm)	250	300	350	400	450	500	600
L(mm)	622	698	787	900	978	1075	1230
H(mm)	750	913	913	1035	1035	1300	1370
H1(mm)	510	600	600	685	685	880	950